

Substation Wide Area Networking Case Study

The following is a case study on the feasibility and benefits of the Integration of Substation Automation and Wide Area Networking.

Project Background

The project was to implement a data acquisition system that would allow SaskPower to properly manage and administer an Interruptible Rate for a Large Industrial Customer. The customer, a Pipeline company operates an oil pipeline that crosses the entire province of Saskatchewan. SaskPower and the pipeline company had negotiated a Non-Firm Power contract which consolidated all of the pipeline companies metering points into 1 Interruptible Load rate.

The Project Challenge

To properly administer this rate SaskPower required the ability to communicate on a real time basis to all of the customers the metering points. This would allow SaskPower to know the pipeline customer's current load and thus evaluate how much load could be realized by having the customer curtail load. The real-time metering information is also required to confirm whether the customer has indeed complied with the Load Curtailment request for billing purposes.

As this pipeline crossed through mostly rural areas of the province of Saskatchewan, expanding the utilities existing dedicated communication system to these sites would be extremely expensive. The Local Telecommunication Company, SaskTel Mobility offered two possible wireless communication solutions, one option utilizing their province wide Ericsson Mobile Data Network (EDACS) and the other using their Cellular Digital Packet Data Network (CDPD). Both options offered a very low initial capital cost. All that was required was the purchase of special modems. These modems emulate the functionality of traditional land line modems therefore any remote devices capable of working over traditional land line dialup networks can work over these wireless networks.

The benefit of low initial capital cost however could be easily lost with the potentially larger operational costs. Both communication options EDACS and CDPD utilized rates that were based on a charge per packet of data. As a result, these solutions did not easily lend themselves to situations where large amounts of data must be constantly transferred across the network. This project did not have a large data transfer requirement. This project did however require the ability to communicate with all remotes simultaneously so the utility could obtain an accurate snapshot of the customers current total load.

To resolve these communication challenges implementing an intelligent event reporting protocol was critical. The choice was made to utilize Distributed Network Protocol 3.0 (DNP 3.0) rather than other protocols such as Modbus. DNP 3.0 is an event reporting protocol that includes sophisticated features such as Unsolicited Reporting. Unsolicited Reporting is where remotes can spontaneously report key events to the Master, independent of Master Station poll request. Utilizing these DNP 3.0 features, Demand Side Solutions Inc. was confident we could effectively communicate with all the remotes in a very timely and efficient manner, meeting all the project goals in a cost effective manner.

System Design

The decision was made to utilize the CDPD network wherever digital cellular coverage was available due to the performance benefits. The remainder of this report focuses exclusively on the CDPD portion of the system. Below is a diagram of the system design.

SaskPower Interruptible Rate Management System

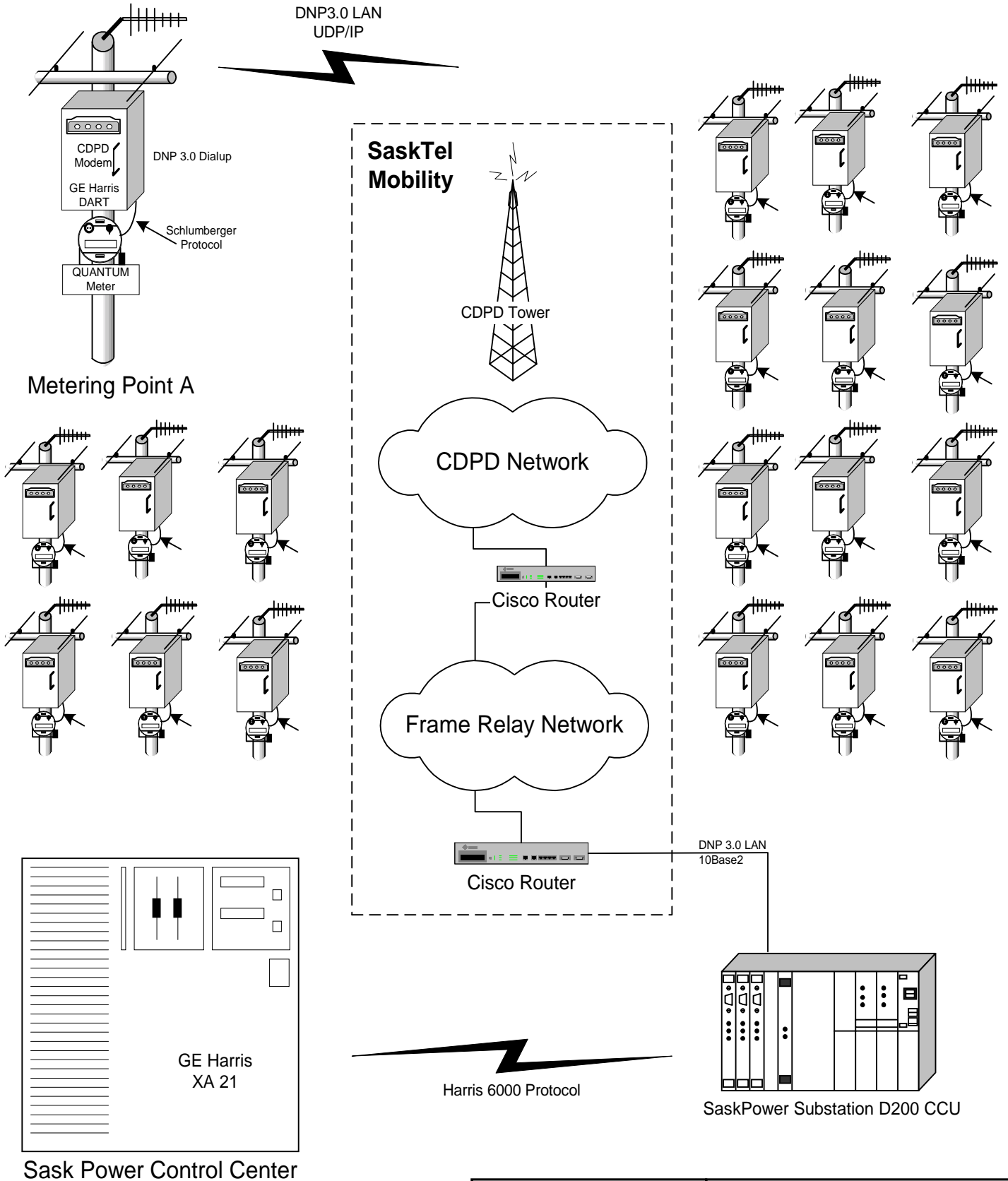

Edit Date: 2/10/99 10:17:46 PM

Description:

DNP LAN-WAN

Rev: 0

Creator: Administrator

Filename: Drawing2

Demand Side Solutions Inc.

The equipment utilized by SaskPower for this project was the Schlumberger Quantum Meters and GE Harris Remote Terminal Units.

Each remote site would include a GE Harris Poletop RTU (DART) and a Schlumberger Quantum Meter. The DART polls the Quantum meter using the Quantum meters protocol to obtain real-time metering information. This communication interface also allows the utilities billing system to dialup and interrogate the Quantum meter via the RTU. The DART also acts a protocol converter, converting the metering data into DNP 3.0 data. The DART's DNP3.0 implementation supports Unsolicited Reporting via a dialup interface.

A GE Harris D200 Substation Control System was utilized as the Master Station data concentrator/protocol converter for this system. As mentioned earlier the project specified the need to concurrently communicate with all 20 remotes at the same time. This requirement basically meant the D200 SCS would need to be expanded to include 20 serial ports connected to 20 CDPD modems. The recent publication of the DNP LAN-WAN standard (basically DNP 3.0 protocol over TCP/IP and UDP/IP) represented an excellent opportunity of increasing the Master Station's system performance while reducing the total system cost. The decision was made add an Ethernet card to the D200 and network it directly into SaskTel Mobility CDPD network utilizing the DNP 3.0 over UDP/IP standard. This single network connection eliminated the need for any serial ports and modems at the Master Station.

System Performance

Performance of the system has proved to be exceptional. Many benefits of the system design were responsible for this performance.

DNP 3.0

As mentioned earlier the advanced Event Reporting and Unsolicited Event Reporting capabilities of DNP 3.0 can almost eliminate the requirement of Master Station polls. This effectively minimized the traffic on the CDPD network, a key benefit when a pay per packet communication networks such as CDPD.

Also the time synchronizing and time stamping capabilities of DNP 3.0 provided key benefits. The ability to time synchronize all the DARTS to the Master Station clock via the CDPD network allowed for accurate time stamped status and analog change information. This timed stamped data is critical for providing a quality audit trail of the operation of the system.

Select-Check-Operate control functionality is also key when performing utility controls. This need can be even more critical when communicating over digital communication networks than it is over traditional dedicated analog links. This is due to variable communication delays that can occur over digital networks.

DNP LAN-WAN

The DNP LAN-WAN interface directly into SaskTel Mobility CDPD network also provided key benefits. Beside the speed benefit of the LAN, the networking layers effectively manage all the collision avoidance issues that can complicate the implementation of Unsolicited Reporting over Radio Systems.

As the DNP LAN-WAN standard is based on open standards such as TCP/IP the integration to SaskTel Mobility's network was straightforward and could use standard commercial networking hardware.

CDPD

CDPD provides substantial benefits over land lines. Besides the previously mentioned benefit of minimal capital cost of having a land line installed the CDPD provides a constant virtual connection. As a result the connect time with CDPD is 2 to 3 seconds where it is typically 30 to 40 seconds over a land line. As a result an Unsolicited Response messages could be completed in under 10 second. Baud rates over the CDPD network also were impressive, operating effectively at 19200 KBPS. Also the encryption features of CDPD provides a high level of data security.

Review of Terminology

DNP - Distributed Network Protocol.

Open standard, non-proprietary SCADA protocol

CDPD -Cellular Digital Packet Data.

Open standard for two-way wireless data communication over high-frequency cellular telephone channels. Allows data transmissions between a remote cellular link and a NAP (19.2Kbps)

NAP - Network Access Point.

Location for interconnection of Internet service providers in the US for the exchange of packets.

Review of Terminology

Frame Relay

Industry-standard, switched data link layer protocol that handles multiple virtual circuits using HDLC encapsulation between connected devices. Frame Relay is more efficient and considered to be a replacement of X.25.

TCP - Transmission Control Protocol.

Connection-oriented transport layer protocol that provides reliable full-duplex data transmission.

TCP is part of the TCP/IP protocol stack.

Review of Terminology

UDP - User Datagram Protocol.

Connectionless transport layer protocol in the TCP/IP protocol stack. UDP is a simple protocol that exchanges datagrams without acknowledgments or guaranteed delivery, requiring that error processing and retransmission be handled by other protocols.

IP - Internet Protocol.

Network layer protocol offering a connectionless internetwork service. IP provides features for addressing, type-of-service specification, fragmentation and reassembly, and security.

About the Author

This paper was prepared by Ameen Hamdon, P. Eng., Managing Partner, Demand Side Solutions Inc. Mr. Hamdon has a B.Sc. Electrical Engineering with 11 years electric utility SCADA experience. He is a voting Member of DNP 3.0 Technical Committee.

Demand Side Solutions Inc. Company Information

Demand Side Solution Inc. is a vendor independent engineering firm that specializes in electric utility transmission and distribution SCADA systems

References

- DNP LAN-WAN Document
- Microsoft Encarta
- Cisco Documentation CDROM